

Live Events

version 1

The diagram below documents a live, multi-day music festival setup – with over 20 cameras and 100,000 attendees – where six editors trim footage captured during the event’s performances into packages that play on large screens as stage hands change out equipment between acts. This ultra-fast turnaround requires parallel efforts from multiple video professionals.

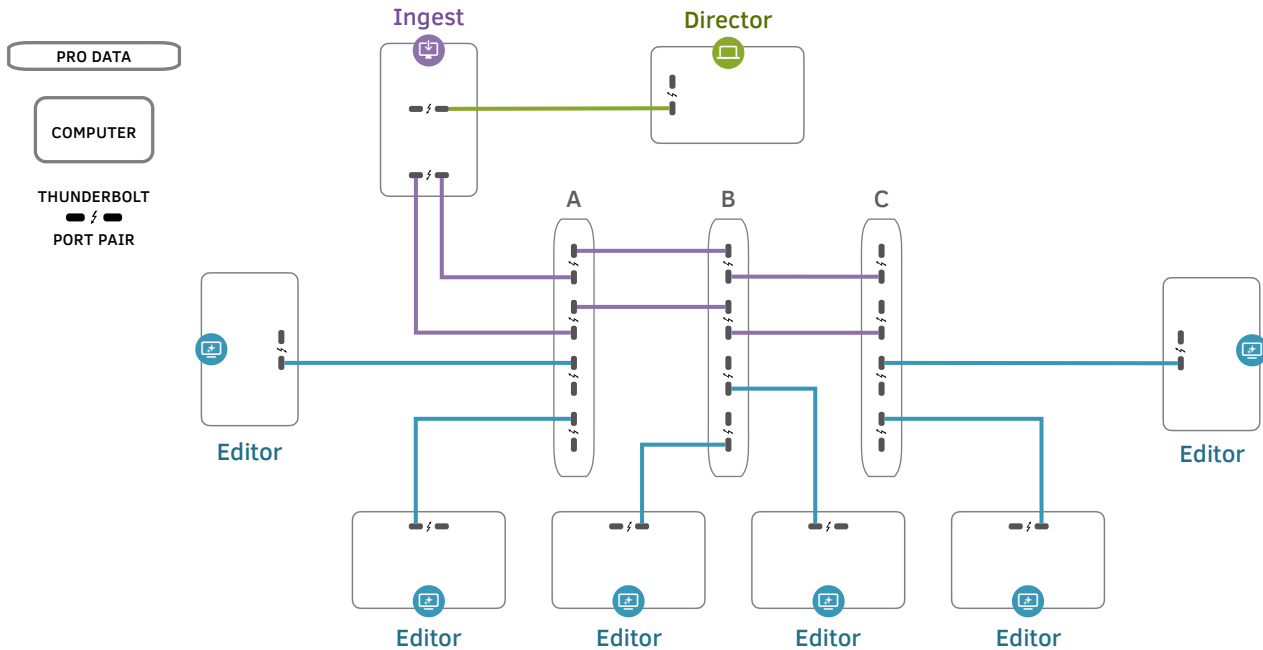

Ingest is *dual-pathed* for ultimate performance to all three Pro Data devices via *daisy-chain*, handing off containers to six **Editors** in teams of two per device. **Director** laptop is connected to the Ingest station via Thunderbolt-over-IP.

Using this set up, the team was able to tear through several gigabytes of multi-cam footage, assembling key moments into reels mere moments after each act left the stage. During what would typically be a break in the action, playing high-

lights of each performance maintained the energy and enthusiasm of the crowd, and kept streaming audiences entertained online.

Below is an example of how this setup can scale out to nine Pro Data devices and 18 editors by using an Ingest computer with more Thunderbolt ports. For more examples of how Pro Data can multiply your team’s efficiency, visit us at iodyne.com

